

# Handle Installation Instructions

FOLD ON THIS LINE

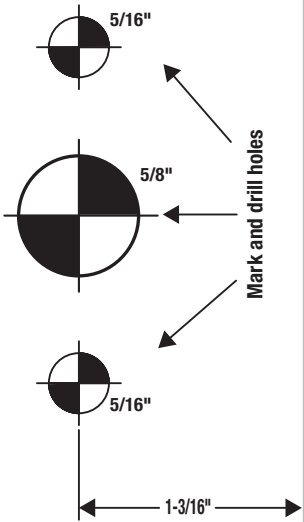

FOLD ON THIS LINE

Fold along gray lines and place around edge of door

FOLD ON THIS LINE

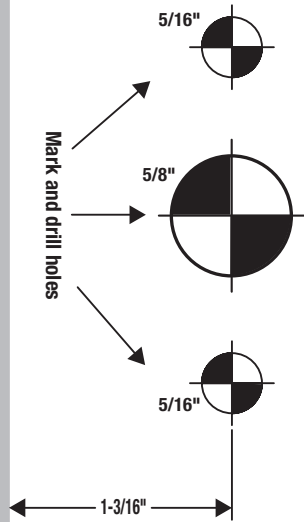

FOLD ON THIS LINE



## DRILLING INSTRUCTIONS

1. Cut along dotted line to separate template.
2. Tape template around edge of door at desired height (Fig 1). **Caution: Raise or lower template so that in any position, inside latch will not hit entry door handle or lock.**
3. Mark position of the six holes with center punch. Pre-drill each hole with 1/8" bit. Remove template.
4. Using 5/16" and 5/8" drill bits, bore the three holes from each side of door. Remove burrs from holes.

## LATCH INSTALLATION INSTRUCTIONS (Fig. 2)

1. Insert spindle into outside handle.
2. Push this assembly through drilled holes from the outside of door. With the inside latch in the unlocked position, slide inside latch onto spindle on inside of door. Secure firmly with #6-32 x 1-11/16" machine screws. **Caution: Do not overtighten screws as this may cause handle to bind.**
3. Position strike on entry door frame so that it engages inside latch. Attach using two #6 x 1-1/4" screws. If needed, use enclosed shims to extend strike.

FIGURE 1

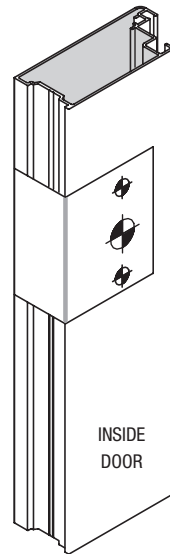

FIGURE 2

